

未注公差/General tolerances (mm)													0.1/10
0	>3	>6	>10	>18	>30	>50	>80	>120	>180	>250	>315	>400	
~ 3	~ 6	~ 10	~ 18	~ 30	~ 50	~ 80	~ 120	~ 180	~ 250	~ 315	~ 400	~ 500	>500
±0.12	±0.18	±0.22	±0.26	±0.31	±0.37	±0.57	±0.80	±0.93	±1.05	±1.15	±1.60	±2.20	±2.50

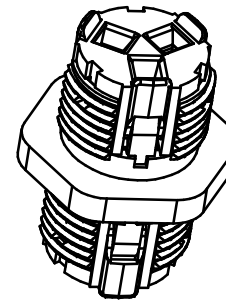
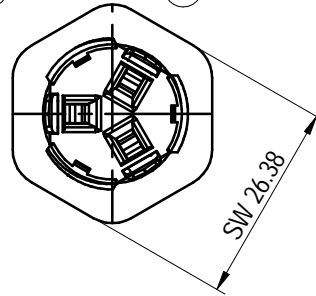
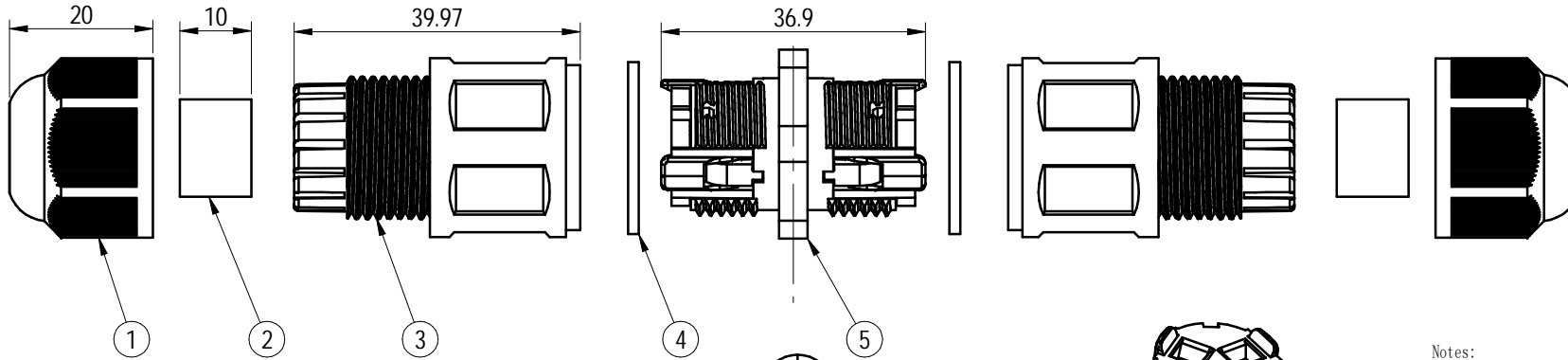
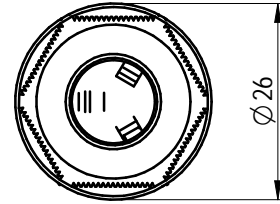
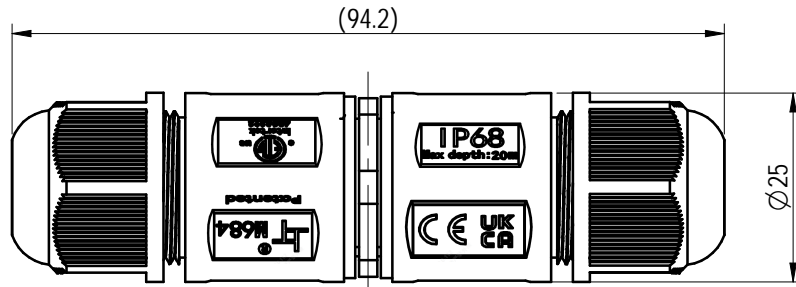

- Notes:
1. 额定电压电流: 450V/24A;
 2. 接线范围: 0.5-2.5mm² / 20AWG-14AWG
 3. 芯数: 3pole;
 4. 剥线长度: 10mm (0.5~1.0mm²) / 15mm (1.5~2.5mm²)
 5. 工作温度: -20~105℃;
 6. 螺帽推荐拧紧扭矩: 3.8Nm;
 7. 符合RoHS环保要求;

ITEM	NAME OF PART	MATERIAL	NOTES
5	connector		
4	gasket		
3	housing	Nylon +PC	
2	cable sealing		
1	cap	Nylon +PC	

		MATERIAL: 材质	SURFACE/COLOR: 表面处理	
		MAT NO./REV: 物料编码 / 版本	MAT STATUS: 物料状态	
APPD: 核准人	核准日期	NAME		
CHKD: 审核人	审核日期	YX-M20-03P-SL8002-00Z (H)		
DRFT: 设计人	设计日期	DRAWING NO.	TYPE	DRAWING STATUS
			CUSTOMER DRAWING	图纸状态
			SCALE	SHEET
			2:1	1/1

图纸版本	ECN	变更描述	设计人	设计日期
REV	ECN	DESCRIPTION	DRFT	DATE

Transfer or duplication of this document as well as the utilization or communication of its contents are prohibited unless explicitly authorized. All rights reserved for patent, utility model or design registrations. 除专利、实用新型、外观设计、发明专利、软件著作权、集成电路布图设计专有权、商业秘密等权利外，本公司保留对涉及发明、实用新型、外观设计、集成电路布图设计等权利的所有权。